

The role of technology in mathematical modelling

Michael de Villiers, Mathematics Education, University of Durban-Westville, Durban 4000

"It is dangerous to assume that skills from one era will suffice for another. Skills are tools. Their importance rests on the needs of the times. Skills once considered essential become obsolete, and this is likely to increase in pace and scope as advances in technology revolutionize our individual, social and economic lives. Necessary new skills arise from the dimensions of the mathematics pertinent to an age of ... micro electronic wonders." — NCTM (1980)

Introduction

The secondary school curriculum has traditionally focused almost exclusively on developing pupils' manipulative skills (e.g. simplifying, factorising, solving equations, differentiation, etc). This focus was in part due to the pervasive belief amongst teachers (and curriculum developers?) that such technical skills were essential prerequisites for problem solving and mathematical modelling, and therefore first had to be mastered. Now, however, the wide availability of graphics calculators and computer programmes is seriously challenging this "Theory & manipulative skills → Applications & Problem solving" approach.

In what follows a brief discussion of the nature of mathematical modelling will be given, followed by five examples of the use of computer software in solving practical problems that the author has successfully used with his mathematics education students (prospective senior primary and junior secondary teachers).

The nature of mathematical modelling

The process of mathematical modelling essentially consists of three steps as illustrated in Figure 1, namely, (1) construction of the mathematical model, (2) solution of the model and (3) interpretation and evaluation of the solution.

During the construction of the model several processes are often necessary, for example:

- the making of appropriate assumptions to simplify the situation
- data often has to be collected, tabulated, graphed, transformed, etc.
- identification and symbolization of variables
- the construction of suitable formulae and/or representations like scale drawings, etc.

During the solution process, we obviously apply mathematical techniques such as factorisation, differentiation, solution of equations, etc. Lastly, in the interpretation

and evaluation of the solution we need to check whether it is realistic by critically comparing it with the real world situation.

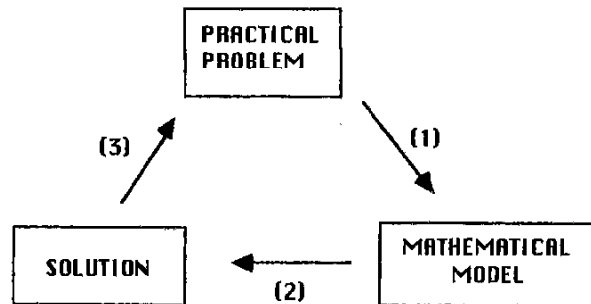

Figure 1

As will be shown later on, new computer software can greatly assist us with the routine manipulations involved in the second step once an appropriate model has been constructed. However, the computer is usually of very little assistance in the first and last steps. Here human ingenuity and understanding is absolutely essential – if a model is inappropriate, the computer may produce an answer which is completely senseless. Computers (and calculators) can only do what they are told and are dependant on the accuracy of the data or model which is fed into them. Essentially, computers (and calculators) are rather stupid and cannot think for themselves: we have to do that for them. Computer scientists have a very sound saying, namely: GIGO, which means "Garbage In – Garbage Out".

The availability of computer software (and calculators) that can aid us with the second step therefore strongly challenges the traditional approach which emphasises technical and manipulative skills at the cost of developing skills in model construction and interpretation. In the global society where computers in the workplace are becoming more and more pervasive, one's "matheracy" should no longer be measured so much in terms of one's ability to do routine manipulative skills by hand, as in competency in Steps (1) and (3), as well as with proficiency in handling modern technology (for example computer software, calculators, etc.) during Step (2). It is time to acknowledge that in modelling,

Step 2 is merely a means to an end, and should not be regarded as an end in itself.

In modern applied mathematics, calculators and computers are absolutely essential tools of the trade, just as the hammer and saw is to the carpenter or the pan and the pot is to the chef. It is simply unthinkable of a carpentry or a catering course without the appropriate tools and some practical work.

Example 1

"A man is 20m from a bus stop when the bus starts pulling away with an acceleration of 1m/s^2 (see Figure 2). At the same time, the man starts running with a speed of 6m/s . Will the man catch the bus? If so, when? If not, what is the closest he gets to the bus?"

Let us take as origin the initial position of the man 20m from the bus stop. Then from science, we have that the distance covered by the man after x seconds is given by

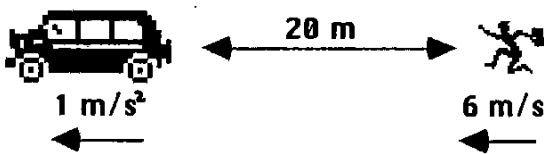

Figure 2

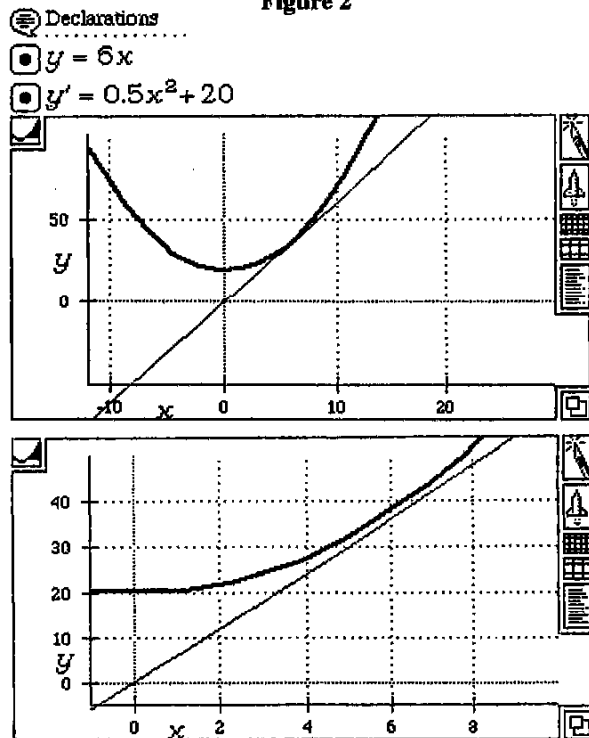

Figure 3

$= 6x$, and that of the bus is given by $y = \frac{1}{2}x^2 + 20$. The

problem is therefore now reduced to finding out whether the graphs of these two functions intersect. Plotting these two graphs on the same axis on *Theorist* (or a graphics calculator) and zooming in, one can immediately see that they do not intersect as shown in Figure 3. (Note that one must zoom in close enough otherwise it may appear as if they touch). Therefore the man will not catch the bus. (An obvious follow up question is to ask at what speed does he need to run to do so).

The shortest distance to the bus can be found by simply plotting the graph of $y = \frac{1}{2}x^2 + 20 - 6x$ to see that it obtains a minimum value when $x = 6$ seconds and $y_{\min} = 2\text{m}$ (see Figure 4). One can even easily differentiate $y = \frac{1}{2}x^2 + 20 - 6x$ on *Theorist* and plot the graph to determine where it intersects the x -axis.

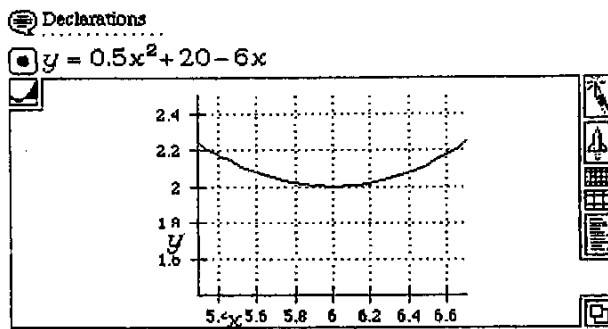

Figure 4

Notice that when using technology as in the above example, it is certainly not a prerequisite that one already knows quadratic theory in detail (e.g. meaning of discriminant, coordinates of turning point, etc.). With computer software and graphics calculators, one need therefore not wait until all the theory is adequately developed before giving pupils realistic problems like these. (It is assumed here that pupils have already done the modelling of the relevant formulae $s = vt$ and $s = ut + \frac{1}{2}at^2$ in science). This problem is also a good example of the interesting applications that can be found not only in science, but also in other school subjects like geography, economics, accountancy, etc. We ought to stop teaching mathematics in complete isolation from other subjects, but also demonstrate its value across the curriculum.

Example 2

"A camper has a campsite in a large flat clearing next to a straight river. He is at point A (200m from the river and 570m from his tent), and his tent is at point B (380m from the river). He sees a large spark leap from his campfire and set his tent aflame. The camper has an empty pail already in his hand. At

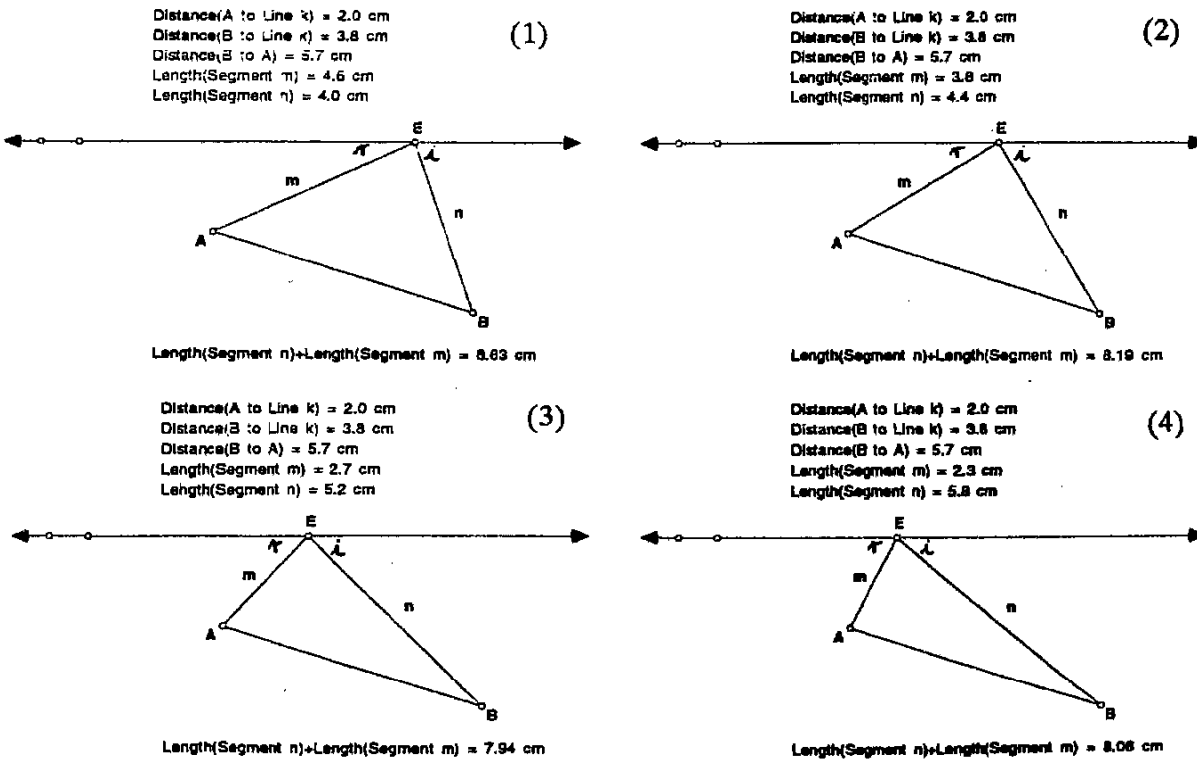

Figure 5

what point E on the river should he fill his pail in order to make the shortest possible path to put out the fire?"

This is a fairly well-known problem and is often formulated in different ways. Using a dynamic geometry software package like *Sketchpad* or *Cabri* one can easily construct a dynamic model of the situation as shown in Figure 5(1). By selecting and dragging point E from right to left along the line one can see how the total distance (n + m) continuously decreases until it reaches a minimum value of about 7,94 cm (794m) as shown in Figure 5(3), after which it starts increasing again. One could then simply measure the distance of E to the perpendicular from A to the river, to determine where the camper should fill his pail.

One could also further explore the solution by continuously measuring the angles between EB and the river ($\angle i$), as well as the angle between EA and the river ($\angle r$), to find that the optimal solution is found when $\angle i = \angle r$. Of course, this condition could then be explained in the usual manner in terms of a reflection and that the shortest distance between two points is a straight line.

An algebraic approach to this problem would be to first determine the distance FG which is the same as AD

$= \sqrt{570^2 - 180^2} = 540,83$ (see Figure 6). Then setting $FE = x$ we need only minimize the function:

$y = \sqrt{200^2 + x^2} + \sqrt{380^2 + (540,83 - x)^2}$ to obtain the desired solution. Again by using a computer programme like *Theorist* (or a graphics calculator) we can easily plot this graph as shown in Figure 7 and

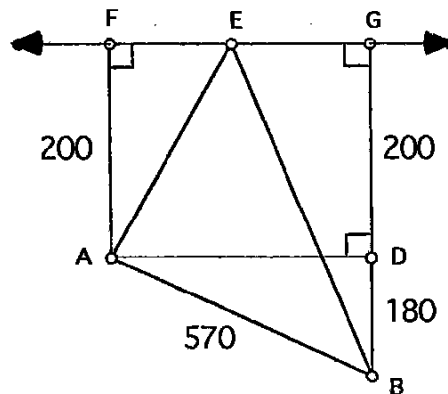

Figure 6

zoom in to its turning point to read off its coordinates as approximately (187;793). Or alternatively, we can simply click the differentiation button on *Theorist* to differentiate the function (it only takes about 2 seconds to do this) and then plot its graph as shown in Figure 8. Again by zooming in to where the graph of the differential equation cuts the x-axis, we easily find the optimal solution when $x = 186,49$ using *Theorist's* "Find Root"-facility.

Declarations

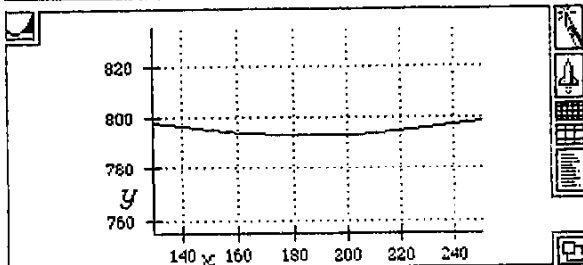
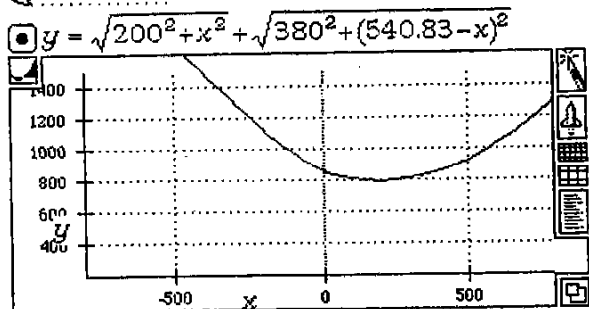

Figure 7

Note that as before, with the availability of powerful software such as *Theorist*, apart from knowing Pythagoras and having a good conceptual understanding of graphs and the meaning of differentiation, it is clearly no longer a prerequisite to know the chain rule and to have technical proficiency in applying it to be able to solve a problem like this.

Example 3

"Consider the same situation as in Example 2, but with a circular dam with radius 300m instead. If the points A and B are respectively 500m and 680m from the center of the dam, and the distance between them is 560m, at what point E on the dam should he now fill his pail in order to make the shortest possible path to put out the fire?"

Again using *Sketchpad* one can again easily construct a dynamic model of the situation as shown in Figure 9. By moving point E on the circumference of the circle, we obtain a minimum total distance of about 703m. By moving at an angle of 29° in relation to AC he would therefore arrive at the desired position of E.

An algebraic approach could be to first determine: $\angle C = \arccos(560^2 - 500^2 - 680^2) / (-2 \cdot 500 \cdot 680) = 0,9441$

radians. If we let $\angle ACE = x$ we need only express $y = AE + EB$ as a function of x and draw its graph as shown in Figure 10 (zooming in to the appropriate domain). Or alternatively, we can use *Theorist* to quickly differentiate the function, and determine its intersection with the x-axis which gives us $x = 0.405$ radians ($= 23,18^\circ$) as the optimal solution.

The chain rule and differentiation of trigonometric functions are not prerequisites for modelling

Again note that neither the chain rule nor knowledge of how to differentiate trigonometric functions are really absolutely essential to solve this problem algebraically. However, one needs to know that angles have to be measured in radians and how to convert degrees into radians, and vice versa.

Declarations

$y = \sqrt{200^2 + x^2} + \sqrt{380^2 + (540.83 - x)^2}$

$\frac{\partial}{\partial x} y$

$$\Delta \frac{\partial}{\partial x} y = -\frac{-x + 540.83}{\sqrt{(-x + 540.83)^2 + 144400}} + \frac{x}{\sqrt{x^2 + 40000}}$$

$y' = -\frac{-x + 540.83}{\sqrt{(-x + 540.83)^2 + 144400}} + \frac{x}{\sqrt{x^2 + 40000}}$

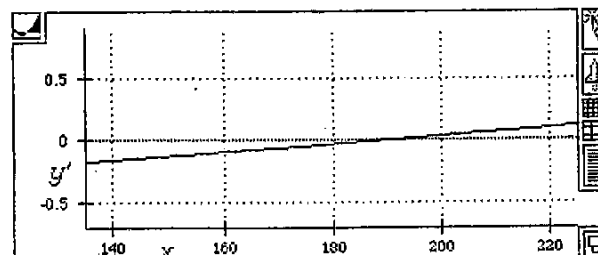
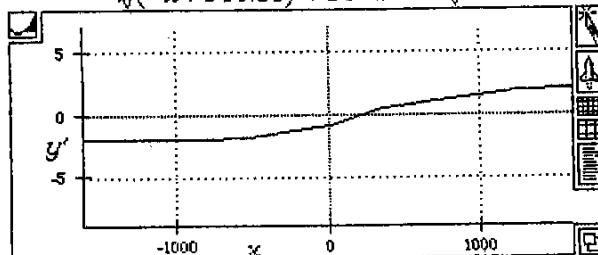

$x = 186.49$

$y' = 0$

Figure 8

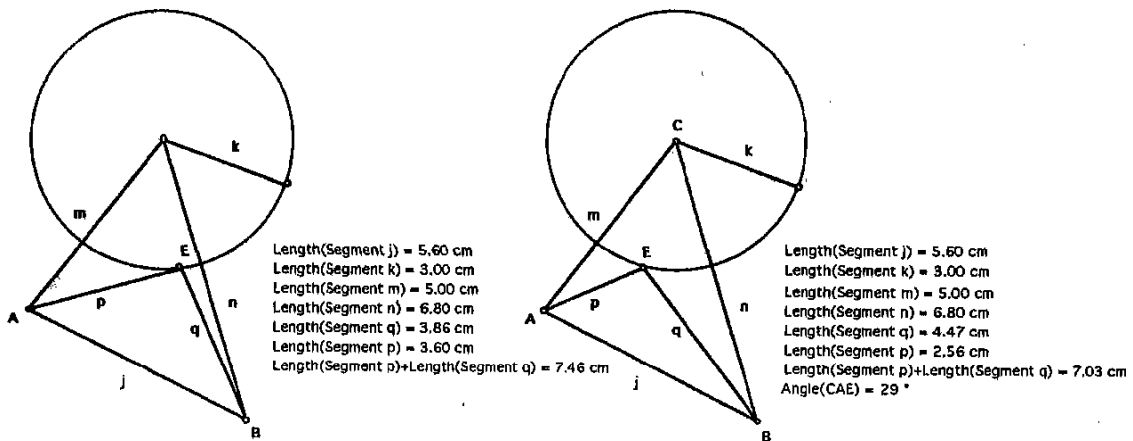

Figure 9

Declarations

$y = \sqrt{500^2 + 300^2 - 2 \cdot 500 \cdot 300 \cos(x)} + \sqrt{680^2 + 300^2 - 2 \cdot 680 \cdot 300 \cos(0.9441 - x)}$

$\frac{\partial}{\partial x} y$

$\frac{\partial}{\partial x} y = -204000 \frac{\sin(-x + 0.9441)}{\sqrt{-408000 \cos(-x + 0.9441) + 552400}} + 150000 \frac{\sin(x)}{\sqrt{-300000 \cos(x) + 340000}}$

$y' = -204000 \frac{\sin(-x + 0.9441)}{\sqrt{-408000 \cos(-x + 0.9441) + 552400}} + 150000 \frac{\sin(x)}{\sqrt{-300000 \cos(x) + 340000}}$

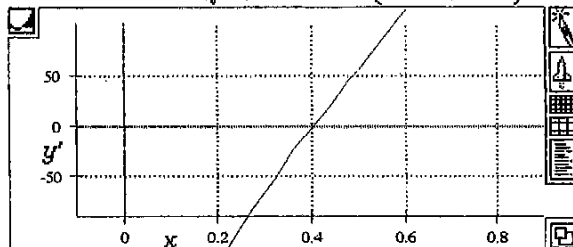

$x = 0.40454$
 $y' = 1.3878 \times 10^{-17}$

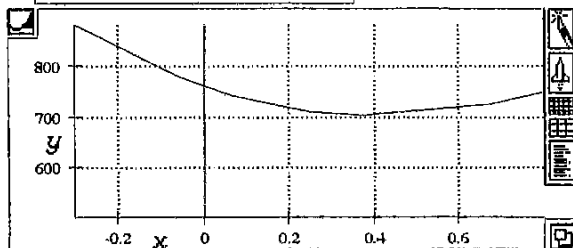

Figure 10

Example 4

"Suppose we want to build a railroad between two towns A and B as shown in Figure 11. The ground to the east of line PQ is marshy and as a result it costs R20 000 per km to build there, as opposed to the R12 000 per km to the west of this line. If PQ is 200 km, where should X be chosen so that the construction of the railroad is as cheap as possible?"

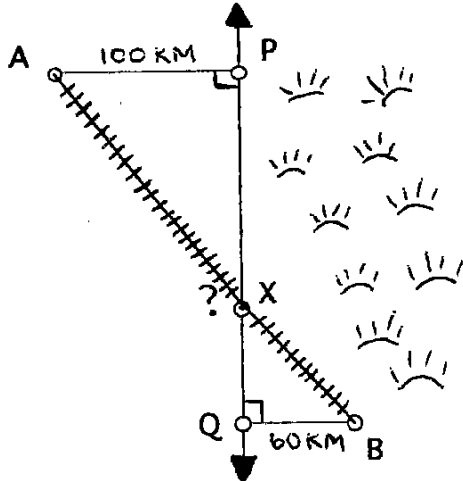

Figure 11

This problem, as well as the next one, have been adapted from Sawyer (1975:21-22). The above problem is a very good one, as my students' usual reaction have been to think that the cheapest solution must be to go to Q, and from there to B. (They clearly do not immediately realize that two opposing variables have to be simultaneously minimized, namely, the distance in the marshy ground versus the total distance). In fact, when I expressed uncertainty and gently suggested earlier this year to a second year class that they should perhaps try some point X further up the line PQ, say 50km from Q, one student flatly refused, saying that it was obvious that route AQB was the cheapest, and that he was not going to waste his time to calculate that cost. Some of the students, however, were willing to calculate the distances using Pythagoras (or using a scale drawing) and consequently the corresponding cost. Greatly to their surprise they found that it was cheaper than route AQB! Eventually, these students were able to convince the Doubting Thomas by having him work through their calculations with them. I then encouraged them to use "guess-and-check" to find the optimal solution.

With Sketchpad it is again quick and easy to construct a dynamic model of the situation as shown in Figure 12 (Scale 1cm:50km) and by moving X up and down line PQ the minimum cost of approximately R3 716 530 is ob-

tained at about $QX = 0,7 \times 50 = 35$ km. Algebraically, we can set $XQ = x$ and use Pythagoras to set up a cost equation as shown in Figure 13. Now we can either draw this graph and zoom in to its minimum or differentiate it with Theorist and then graph the differential equation to obtain the minimum cost when $x = 35,805$ km.

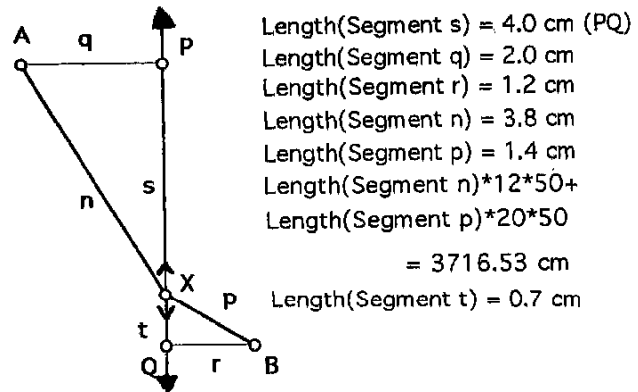

Figure 12

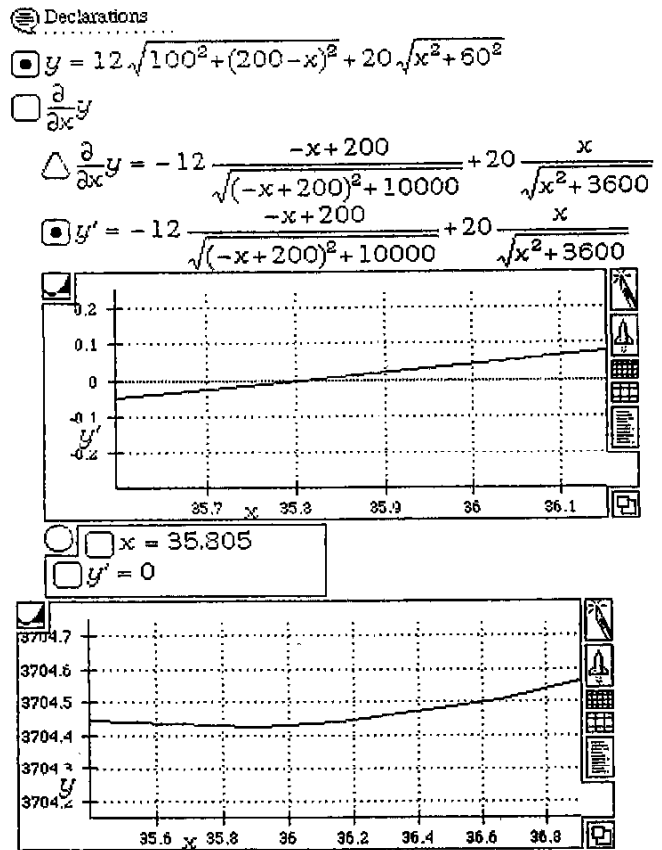

Figure 13

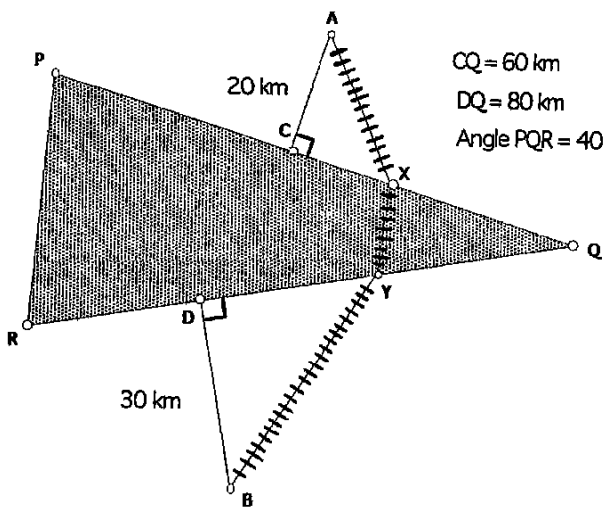

Figure 14

It is perhaps important to point out that some students in the class referred to the above, expressed great interest into how *Theorist* had managed to differentiate this cost-function. (They realized their matric knowledge was inadequate). This then naturally led into a discussion and presentation of the *chain-rule* in a subsequent tutorial by one of the students who has had previous teaching experience, Aurelius Mkhize (although this is normally not dealt with in this course). In this sense,

there seems to be some potential in using symbolic processing software in the so-called "black box" mode where the purpose is the discovery and explanation of how the programme works. (Another example would be to first demonstrate, the factorisation of a quadratic trinomial with such a programme, and then challenging pupils afterwards to figure out how the programme had done it).

Example 5

"Suppose a railroad has to be built between two towns A and B, but a wedge of difficult ground, PQR with $\angle PQR = 40^\circ$, lies between them (see Figure 14). If the cost structure is the same as in the previous problem, what would be the cheapest route for the railway?"

This type of problem regularly occurs in practice, when hilly country lies between towns. In this case, the extra expense would be due to the need to excavate cuttings.

Using *Sketchpad* again as shown in Figure 15, it is quick and easy to move X back and forth along line segment PQ, and also Y along line segment RQ, until a minimum cost of about R1 451 900 is obtained. The corresponding distances XQ and YQ are then respectively 50 km and 53 km. (Note that the cost along route AZB would be about R1 784 200 – so the above solution is a saving of about R332 300).

If we set $XQ = x$ and $YQ = y$, it is not difficult to arrive at an algebraic model as shown in Figure 16. However, the cost function z is now unfortunately dependant on two independent variables x and y . Nevertheless, by using *Theorist's* 3D-graphing facility we can

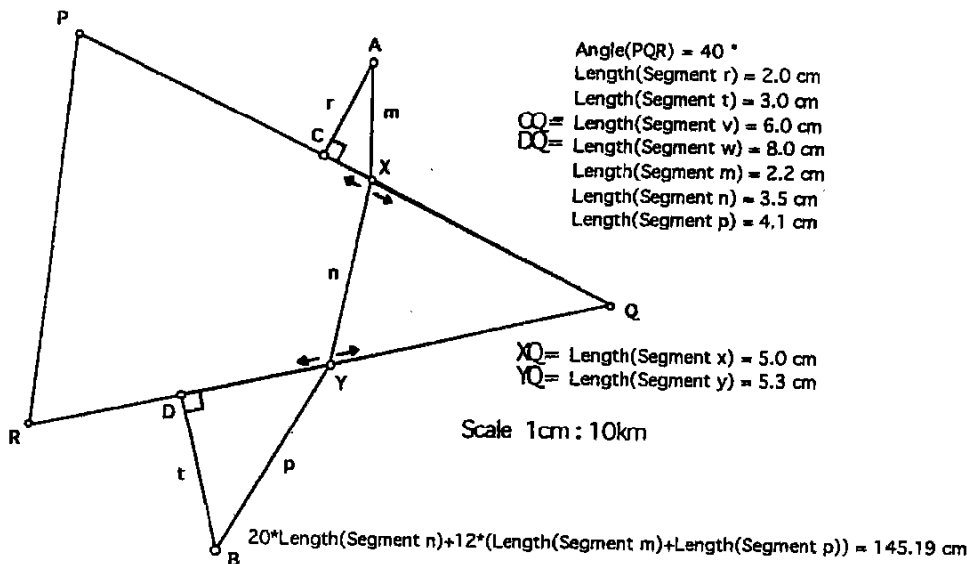

Figure 15

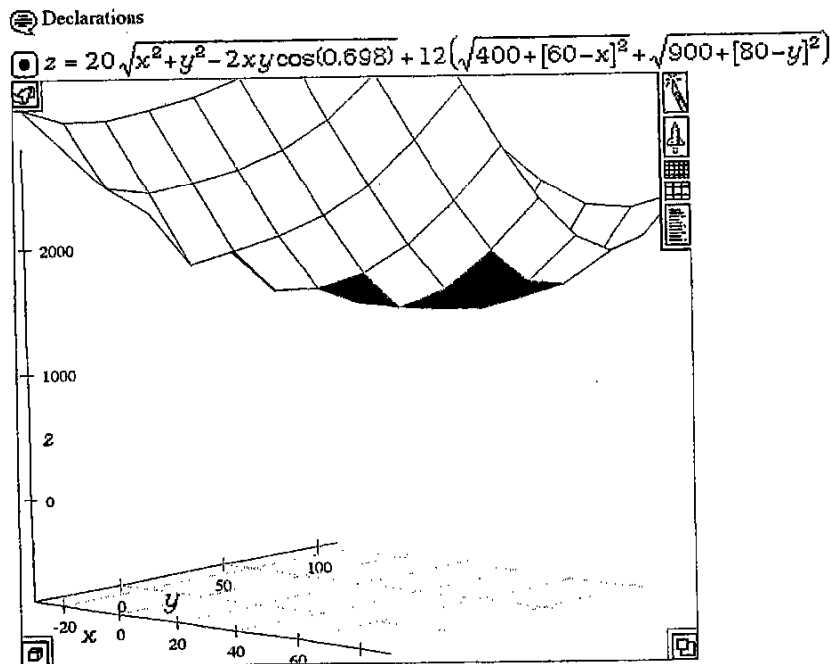

Figure 16

obtain a 3D graph (see Figure 16). By further rotating the three dimensional surface to appropriate side views (looking perpendicularly at the $x-z$ and $y-z$ planes) we can obtain the required values for x and y as about 50 km. Better accuracy can be obtained by zooming in more closely as shown in Figure 17, and then rotating it appropriately. (Note how very jagged the apparently smooth surface has become).

Concluding remarks

When the above problems were presented to my students (including some post graduate HDE's), most of them were completely at a loss of where to start (probably because they have never been exposed to modelling before), so I first encouraged them to try and use scale drawings or numerical and graphical approaches. The tediousness (and often inaccuracy) of these methods certainly made them greatly appreciative of the power of technology when I finally demonstrated the above solutions.

These problems also provided useful contexts for discussing significant digits, rounding off, appropriate choices of scale, as well as elementary ways of simplifying a mathematical model. For example, in Example 4, accuracy to 9 decimals is meaningless - an answer to the nearest R100 (or even the nearest R1000) is probably quite appropriate. The cost calculations in Figure 14 are simplified by using 12 and 20 instead of 12 000 and 20 000, but one must then remember to multiply the final (cost) answer by 1000, as well as by the scale factor of 10 (for the lengths of the line segments).

The above are only few examples of how much computer (and calculator) technology can help us during Step (2) of the modelling process, and by their ability to do routine manipulations quickly and easily, the human mind is freed to be more creative. Other examples of where computer software is becoming more and more invaluable in a modelling context are: linear and dynamic programming, matrices, curve fitting, transformations, integration, fractals, networks, etc.

It is therefore high time our school (and university) curriculum wakes up from its pre-technology slumber, and becomes more relevant with respect to the increasing technologization of society. By spending less time on boring drill of highly complicated manipulative skills, more time can be made available for modelling and problem solving. It seems reasonable that pupils (and students) today need to cover only the simpler cases of manipulative and solution procedures to provide them with an adequate understanding of computer-generated results.

With technology like this, it is furthermore much easier to follow a spiral approach to the modelling of certain problems in the curriculum. For example, one could have the following approach to Example 3:

- Senior primary* - use of dynamic geometry software and/or numerical approach using calculator
- Junior secondary* - algebraic approach with plotting of cost function by graphic calculator and/or computer programme
- Senior secondary* - differentiation of cost function by symbolic processor and plotting of its graph.

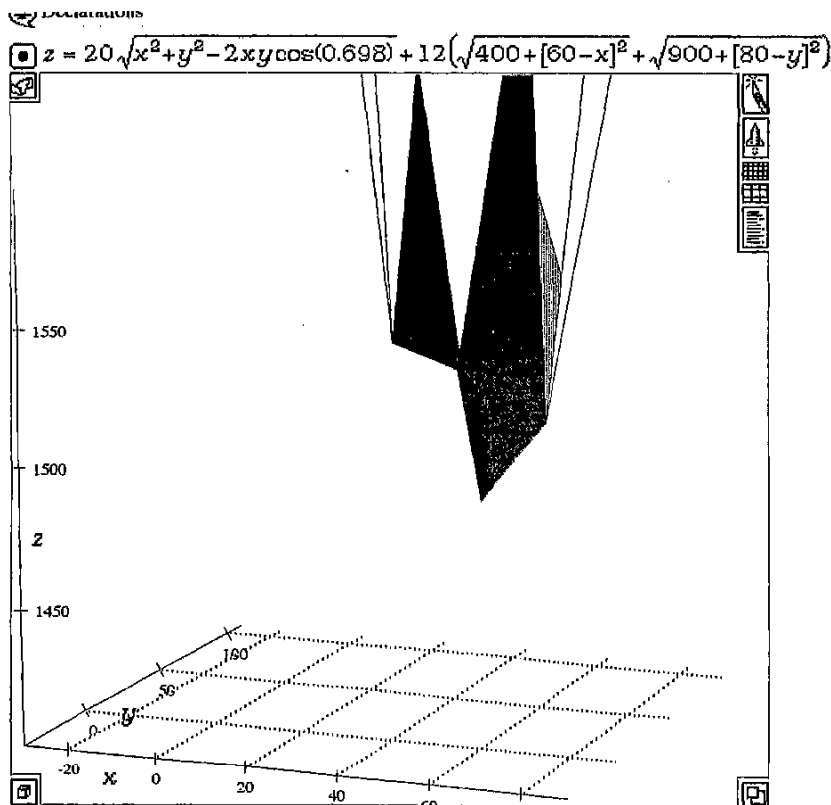

Figure 17

Of course one could argue that many school children in South Africa do not even have calculators, not even to speak of graphic calculators and computers. So what relevance do the arguments presented here have for the South African school situation?

Personally, I believe it is absolutely imperative that our education authorities start addressing this situation as a matter of great urgency in the short term, firstly, by providing all primary school children with calculators (which are relatively cheap), and secondly, by providing each secondary school with two or three OHP graphic calculators, depending on the number of teachers and classes. Thirdly, in the medium term, each secondary school ought to be supplied with at least one or two computers which can be used specifically for instructional purposes in mathematics.

Finally, in the long term, each secondary school pupil ought to have a graphics calculator, and regular access to a computer laboratory. Associated with this, radical changes in evaluation, massive in-service training and re-designing of pre-service courses are of course absolutely essential.

Notes

The programmes referred to in the article are available from:

- (1) *Geometer's Sketchpad*: Key Curriculum Press, 2512 Martin Luther King Jr. Way, Berkeley, CA 94704, U.S.A. (Requirements: IBM, 4 Mb RAM, 386 CPU, Windows 3 or Macintosh)
- (2) *Cabri Geometre*: Chartwell Bratt Ltd., Old Orchard, Bickley Rd, Bromley BR112NE, United Kingdom. (Requirements: IBM XT or Macintosh).
- (3) *Theorist*: Prescience Corporation, 939 Howard Street, #302, San Francisco, CA 94103, U.S.A. (Requirements: Macintosh).

Other programmes similar to the above, are *Geometry Inventor*, *Mathematica* and *MathCad*.

References

- National Council of Teachers of Mathematics. (1980). *An agenda for action: recommendations for school mathematics in the 1980's*. Reston, VA.
- Sawyer, W.W. (1975). *Mathematician's delight*. Gt. Britain: Penguin Books.